



REGIONAL DISTRICT of Fraser-Fort George

INVITATION TO TENDER ES-24-14

SUPPLY AND INSTALL PHASE ONE PARKING LOT FENCING 155 GEORGE STREET, PRINCE GEORGE

- Date Issued:** September 4, 2024
- Closing Location:** Regional District Office
3rd Floor, 155 George Street,
Prince George, BC V2L 1P8
- Mandatory Site Meeting:** September 10, 2024 at 11:30 am
- Closing Time:** September 18, 2024
2:00 pm p.m. (Pacific Standard Time)
No Public Opening
- Inquiries:** Email Gina Layte Liston at gina.layteliston@rdffg.bc.ca
- Note:** Late submissions will not be considered

TABLE OF CONTENTS

PART A – INTRODUCTION	3
TENDER DOCUMENTS	3
TENDER SUBMISSION AND CLOSING LOCATION AND TIME:.....	3
PART B – INSTRUCTIONS TO TENDERERS.....	5
ACKNOWLEDGEMENT LETTER	5
SITE MEETING.....	5
TENDER PROCESS	6
PART C – CONTRACT CONDITIONS	14
APPENDIX A - ACKNOWLEDGEMENT LETTER	22
APPENDIX B – BIDDER CHECKLIST	23
APPENDIX C – TENDER FORM	24
APPENDIX D - SCHEDULE OF PRICES – TENDERED PRICE.....	26
APPENDIX E - LIST OF CONTRACTOR'S PERSONNEL.....	27
APPENDIX F - LIST OF SUBCONTRACTORS.....	28
APPENDIX G - TENDERER'S EXPERIENCE IN SIMILAR WORK	29
APPENDIX H - CONFLICT OF INTEREST STATEMENT	30
APPENDIX I - GOODS AND SERVICES TAX INFORMATION.....	31
APPENDIX J - CONTRACT AGREEMENT	32
APPENDIX K – SPECIFICATIONS	34

INVITATION TO TENDER

PART A – INTRODUCTION

The Regional District of Fraser-Fort George (Regional District) invites tenders from qualified contractors to supply and install commercial ornamental fencing at 155 George Street. The Contractor will provide all labour, materials, supplies, and equipment to complete the services specified herein.

TENDER DOCUMENTS

The Invitation to Tender (ITT) documents may be obtained on or after September 4, 2024

- (a) in a PDF (Public Document Format) file format from the Regional District's website at www.rdffg.ca;
- (b) on the BCBid® website at www.bcbid.gov.bc.ca.

All subsequent information regarding this ITT, including amendments, Addendum(s) and answers to questions will also be available as above.

It is the sole responsibility of the tenderer to ascertain that they have received a full set of Tender Documents. Upon submission of their bid, the tenderer will be deemed conclusively to have been in possession of a full set of Tender Documents (listed in Part B, Section 2.1).

Tenders not submitted in strict accordance with these instructions or not complying with the requirements in this ITT may be rejected.

To be considered, Tenders must be signed by an authorized signatory of the Tenderer. By signing the Tender, the Tenderer is bound to statements made in response to this ITT. Any Tender received by the Regional District that is unsigned will be rejected.

The lowest of any Tender will not necessarily be accepted. The Regional District of Fraser-Fort George reserves the right to accept or reject any or all Tenders.

TENDER SUBMISSION AND CLOSING LOCATION AND TIME:

The Regional District will accept Tenders submitted either by direct delivery (hand delivery, courier, or post/mail) or electronically to the Closing Location and Time, as outlined below.

Tenders will be received by the General Manager of Financial Services at the Regional District of Fraser-Fort George, 3rd floor, 155 George Street, Prince George, BC (the "**Closing Location**"), no later than 2:00 p.m. local time on September 18, 2024 (the "**Closing Time**") or by email to purchasing@rdffg.bc.ca. There will not be a public opening for this Tender.

Tenders must be in English and must be submitted using the submission methods below.

The Closing Time and time for this tender is September 18, 2024, at 2:00 p.m.

For Tenders to be submitted by hard copy direct delivery:

Two complete copies of your Tender must be submitted in a sealed envelope with the following information written on the outside of the envelope containing the tender, as well as on the outside of the courier envelope/box (if sending by courier):

1. Attention: General Manager of Financial Services
Regional District of Fraser-Fort George
3rd Floor, 155 George Street
Prince George, BC V2L 1P8
2. Invitation to Tender, ES-24-14 - Supply and Install Phase One Parking Lot Fencing- 155 George Street, Prince George
3. Responding Tenderer's name and address

Facsimile Tenders will NOT be accepted.

For Tenders to be Submitted Electronically, with no Bid Security:

"Prince George Time" will be conclusively deemed to be the time indicated in the electronic timestamp the Tender receives upon delivery to the email address specified herein.

Tenderers must submit all portions of their Tender by email in accordance with the following:

Subject of the file to be: ES-24-14 – Supply and Install Phase One Parking Lot Fencing- 155 George Street, Prince George (Insert Responding Tenderer's Name)

All emailed documents must be in PDF format and should be in one combined file. Tenderers should ensure that the files should not collectively exceed 35MB. Zip the files to reduce the size if needed. Submitting the files via Drop Box, FTP, or similar programs, is not acceptable.

Tenders must be submitted to purchasing@rdffg.bc.ca. DO NOT deliver a physical copy of the tender package to the Regional District of Fraser Fort George.

The Regional District does not assume any risk or responsibility or liability, including in contract or tort (including negligence), whatsoever to any Tenderer:

1. for ensuring that any electronic email system being operated by or for the Regional District is in good working order, able to receive transmissions, or not engaged in receiving other transmissions such that a Tenderer's electronic transmission, including the transmission of an electronic copy of its Tender, cannot be received;
2. for errors, problems or technical difficulties with respect to a Tenderer's electronic transmission, including the transmission of an electronic copy of its Tender;
3. that a Tenderer's electronic transmission, including the transmission of an electronic copy of its Tender, is received by the Regional District of Fraser-Fort George in its entirety or within any time limit specified by this Tender.

PART B – INSTRUCTIONS TO TENDERERS

The Regional District of Fraser-Fort George, hereinafter referred to as the Regional District, invites Tenders for: ES-24-14 Supply and Install Phase One Parking Lot Fencing- 155 George Street, Prince George.

Instructions regarding obtaining the Tender Documents are contained in Part A: Introduction.

Questions relating to the tender or project must be directed to the Project Manager:
Gina Layte Liston, Senior Manager of Environmental Services
Regional District of Fraser-Fort George
155 George Street
Prince George, BC V2L 1P8
Email: gina.layteliston@rdffg.bc.ca

Deadline for question submissions is 5:00 p.m. (local time) on September 12, 2024

Those questions that are determined to be of a common interest to all potential Tenderer's will be summarized and posted as Addendum(s) on the Regional District's website as well as the BCBid® website.

ACKNOWLEDGEMENT LETTER

Upon receipt of this Invitation to Tender, a potential Tenderer should complete and sign the Acknowledgement Letter at Appendix A and email the signed Acknowledgement Letter to Janet Todoruk, jtodoruk@rdffg.bc.ca. A Tenderer who signs and returns the Acknowledgement Letter is not obligated to submit a Tender.

Any Tenderer who does not submit the Acknowledgement Letter will not be sent any Addendum(s), or answers to questions and may be disqualified.

SITE MEETING

All prospective Tenderers must attend the site meeting. The Senior Manager and Utilities Leader (responsible for building maintenance) will provide an overview of the contract expectations and be available for questions pertaining to this ITT. The purpose of the site meeting is for Tenderers to satisfy themselves as to the nature of the work in general, to clarify their understanding of the scope of work, to view the site, to determine specifications, and to have the opportunity to ask questions regarding the project and any other circumstances which may influence their Tender.

Oral questions will be allowed at the Tenderers' meeting. However, questions of a complex nature, or questions where the Tenderer requires anonymity, should be forwarded in writing, prior to the meeting, to the Project Manager.

The Regional District will not, under any circumstances, make accommodations for rescheduling, or holding any additional site meetings or providing individuals access to the sites.

The mandatory site visit will be held at 11:30 am on September 10, 2024 at 155 George Street, Prince George.

TENDER PROCESS

1.0 Definitions

- 1.1 "**Addendum(s)**" means all additional information regarding this ITT including amendments to the ITT.
- 1.2 "**BC Bid**" means the BC Bid website located at www.bcbid.ca.
- 1.3 "**Board**" means the Board of the Regional District.
- 1.4 "**Closing Location**" means the location specified in Part A - Introduction.
- 1.5 "**Closing Time**" means the closing time and date specified in Part A - Introduction.
- 1.6 "**Contract**" means the contract substantially in the form attached to this ITT.
- 1.7 "**Contractor**" means the successful Tenderer to the ITT who enters into a Contract with the Regional District.
- 1.8 "**Form of Tender**" means the form of tender attached to this ITT.
- 1.9 "**ITT**" means the solicitation described in this document, including any attached or referenced appendices, schedules or exhibits and as may be modified in writing from time to time by the Regional District by Addendum(s).
- 1.10 "**Must**" means a requirement that must be met in order for a Tender to receive consideration.
- 1.11 "**Project Manager**" means the Regional District's representative.
- 1.12 "**Regional District**" means the Regional District of Fraser-Fort George.
- 1.13 "**Should**", or "**May**" means a requirement having a significant degree of importance to the objective of the ITT, but which the Regional District would strongly prefer to be fulfilled, and which the Regional District may in its sole discretion elect to treat the failure to fulfill as a grounds for rejection of a Tender.
- 1.14 "**Tender**" means a submission in response to this ITT.
- 1.15 "**Tender Documents**" means the documents listed in section 2.1.
- 1.16 "**Tenderer**" means the person submitting a Tender.
- 1.17 "**Work**" means the total construction and related services required by the Tender documents.

2.0 Tender Documents

2.1 The Tender Documents are:

- (a) Part A – Introduction;
- (b) Part B – Instructions to Tenderers; and
- (c) Appendices:
 - i. Appendix A – Acknowledgment Letter;
 - ii. Appendix B – Bidder Checklist;
 - iii. Appendix C – Tender Form;
 - iv. Appendix D – Schedule of Prices – Tendered Price;
 - v. Appendix E – List of Contractor's Personnel;
 - vi. Appendix F – List of Subcontractors;
 - vii. Appendix G – Tender's Experience in Similar Work;
 - viii. Appendix H – Conflict of Interest Disclosure Statement
 - ix. Appendix I – Goods and Services Tax Information;
 - x. Appendix J – Contract Agreement; and
 - xi. Appendix K – Specifications.

2.2 If there is a conflict between or among the Specifications and the other Tender Documents, the other Tender Documents shall prevail over the Specifications.

3.0 Acceptance of Terms and Conditions

Submitting a Tender indicates acceptance of all the terms and conditions set out in the ITT, including those that follow and that are included in all appendices and any Addendum(s).

4.0 Submission Instructions

4.1 Each Tenderer must complete and provide Appendix A and C through I.

4.2 All prices and notations should be legibly written in a non-erasable medium. Erasures, interlineations, or other corrections should be initialed by an authorized signatory of the Tenderer.

4.3 Subject to any alternatives or options in respect of which the Regional District requests pricing

or other information in an Appendix to the ITT, Tenders are to be all inclusive and without qualification or condition.

- 4.4 The Regional District may, at any time and for any reason, extend the Closing Time by means of a written amendment published on the Regional District's website, at www.rdffg.ca and at BC Bid.
- 4.5 Each Tender must be signed by an authorized signatory or authorized signatories of the Tenderer, as is necessary for due execution on behalf of the Tenderer. Each Tender by a company or partnership should specify the full name of the legal entity submitting the Tender.
- 4.6 It is the sole responsibility of the Tenderer to ascertain that they have received a full set of the Tender Documents. Upon submission of their Tender, the Tender will be deemed conclusively to have been in possession of a full set of the Tender Documents.
- 4.7 If the Regional District, in the Regional District's sole discretion, determines that a clarification, addition, deletion, or revision of the ITT is required then the Regional District will issue an addendum and the addendum will be posted on the Regional District website and BC Bid.
- 4.8 It is the sole responsibility of the Tenderer to check for Addendum(s). Addendum(s) issued during the time of Tendering must be signed by the Tenderer and included with the Tender and will become a part of the Tender documents.
- 4.9 The Regional District will not be responsible for any costs incurred by the respondent which may result from the preparation or submission of documents pertaining to this Tender. Accuracy and completeness of a Tender is the Tenderer's responsibility.

5.0 Discrepancies or Omissions

- 5.1 Tenderers finding discrepancies or omissions in the specifications or other documents herein or having doubts on the meaning or intent of any part thereof, should immediately request in written form, either by email or by mail, clarification from the Project Manager. Upon receipt of the written request for clarification, The Project Manager may, in the person's sole discretion, send written instructions or explanations to all parties registered as having returned the acknowledgement letter, and make amendments to this ITT. No responsibility will be accepted for oral instructions. Any requests must be received prior to September 12, 2024.
- 5.2 It is the responsibility of each Tenderer to thoroughly examine the Tender Documents and satisfy itself as to the full requirements of this ITT and their acceptability to the Tenderer.

6.0 Late Submissions

Tenders will be marked with their receipt time upon receipt. Only complete Tenders received before the Closing Time will be considered to have been received on time. Tenders received late will be marked late and not considered or evaluated. In case of a dispute, the Tender receipt time as recorded by the Regional District will prevail whether accurate or not.

7.0 Changes to Tenders

A Tenderer that has already submitted a Tender may amend its Tender prior to the Closing Time:

- (a) For changes to price only, by submitting an amendment via email or mail at the address identified at the beginning of Part B of this Invitation to Tender, identifying a plus or minus variance to the Tenderer's Tender Price; or
- (b) In all cases, by delivering a completely new Tender in accordance with Part A to this Invitation to Tender, clearly indicating it replaces the previously submitted Tender.

Any such revision must clearly identify the ITT number and the Closing Time. A Tender revision submitted as aforesaid shall effectively amend the Tender and the Regional District shall only review and evaluate the Tender as amended.

8.0 Bid Prices

- 8.1 The Tenderer will be deemed to have satisfied themselves as to the sufficiency of the Tender for the work and the price stated in the Schedule of Prices. These prices will cover all their obligations under the Contract, and all matters necessary to the proper completion and maintenance of the work, and will include the supply of all labour, equipment material, supervision, services, taxes and assessments, together with the Tenderer's overhead and profit, except where otherwise provided elsewhere in this ITT.
- 8.2 Tender prices must remain open for acceptance for a period of 60 days from the Closing Time unless otherwise stated by the Regional District.

9.0 Subcontractors

All Subcontractors, including affiliates of the Tenderer, should be clearly identified in the Tender as per the form attached as Appendix F.

A Tenderer may not subcontract to a firm or individual whose current or past corporate or other interests, may, in the Regional District's opinion, give rise to an actual, perceived or potential conflict of interest in connection with the services described in the Tender. This includes, but is not limited to, involvement by the firm or individual in the preparation of the Tender or a relationship with any employee, contractor or representative of the Regional District involved in preparation of the Tender, participating in evaluation or in the administration of the Contract. If a Tenderer is in doubt as to whether a proposed Subcontractor might be in a conflict of interest, the Tenderer should consult with the Project Manager prior to submitting a Tender. By submitting a Tender, the Tenderer represents that it is not aware of any circumstances that would give rise to a conflict of interest that is actual, perceived or potential, in respect of the Tender.

10.0 Rejection of a Tender

- 10.1 The Regional District may, in its sole discretion, reject any and all Tenders, or accept the Tender deemed most favourable in the interests of the Regional District. The lowest, or any Tender, will not necessarily be awarded.
- 10.2 Tenders which contain qualifying conditions or otherwise fail to conform to the instructions contained in this ITT may be disqualified or rejected. The Regional District may, however, in its sole discretion, reject or retain for its consideration Tenders which are non-conforming because they do not contain the content or form required by the ITT, or for failure to comply

with the process for submission set out in this ITT, whether or not such non-compliance is material.

10.3 The Regional District's intent is to enter into a Contract with the Tenderer who has submitted the best offer. The Regional District reserves the right to accept any or none of the Tenders submitted and will evaluate Tenders based on the best value offered to the Regional District and not necessarily the lowest price. The Regional District reserves the right in its sole unrestricted discretion to:

- (a) accept any Tender which the Regional District deems most advantageous to itself;
- (b) reject any and/or all irregularities in a Tender submitted;
- (c) waive any defect or deficiency in a Tender whether or not that defect or deficiency materially or substantially affects the Tender and accept that Tender;
- (d) reject any and/or all Tender for any reason, without discussion with the Tenderer(s);
- (e) accept a Tender which is not the lowest Tender; and
- (f) cancel or reissue the Tender without any changes.

10.4 Without limiting any other provision of this Tender, the Regional District may, in its sole discretion, reject a Tender submitted by a Tenderer, if the Tenderer or any officer or director of a corporate Tenderer, is, or has been within a period of two years prior to the Closing Time, engaged either directly or indirectly through another corporation or legal entity in a legal proceeding initiated in any court against the Regional District in relation to any contract with, or works or services provided to the Regional District.

11.0 Conflict of Interest

11.1 When submitting a Tender, the Tenderer must complete, sign and include with their Tender a conflict of interest disclosure statement (Appendix H).

11.2 Without limiting any other provision of this ITT, the Regional District may reject a Tender based on an actual, potential or perceived conflict of interest.

The Regional District may reject any Tender where:

- a. one or more of the directors, officers, principals, partners, senior management employees, shareholders or owners of the Tenderer, is an officer, employee or director of the Regional District or a consultant involved in the procurement process, or is a member of the immediate family of an officer, employee or director of the Regional District or a consultant involved in the procurement process; or
- b. in the case of a Tender submitted by a Tenderer who is an individual person, where that individual is an officer, employee or director of the Regional District or a consultant involved in the procurement process, or is a member of the immediate family of an officer, employee or director of the Regional District or a consultant involved in the procurement process.

A Tenderer who has any concerns regarding whether a current or prospective employee, advisor or member of that Tenderer is, or may be, a Restricted Party, is encouraged to request an advance decision by submitting to the Project Manager, not less than ten working days prior to the Closing Time, by email, the following information:

- (a) names and contact information of the Tenderer and the person for which the advance opinion is requested;
- (b) a description of the relationship that raises the possibility or perception of a conflict of interest or unfair advantage; and
- (c) copies of any relevant documentation.

The Regional District may make an advance decision regarding whether the person is a Restricted Party, and whether the Regional District will reject a Tender based on the information provided.

12.0 Tender Evaluation

12.1 The purpose of this ITT is to select a Tenderer with the capability and experience to efficiently and cost effectively complete the work described in this ITT.

12.2 The Regional District shall be the sole judge of a Tender and its decision shall be final. The Regional District staff shall use the following criteria to evaluate tenders received:

- a. Tenderer's Qualifications, Experience, and References 40 points
- b. Past Work Experience with the Regional District 20 points
- c. Tender Price 40 points

TOTAL 100 points

12.3 The Tenderer acknowledges that the Regional District may rely upon criteria that the Regional District deems relevant even though such criteria may not have been disclosed to the Tenderer. By submitting a Tender, the Tenderer acknowledges the Regional District's right under this clause and absolutely waives any right of action against the Regional District for the Regional District's failure to accept the Tenderer's Tender, whether or not such right of action arises in contract, negligence, bad faith or any other cause of action.

12.4 Notwithstanding any other provision in this ITT, the award of a Contract by the Regional District may be subject to the availability of funding and the approval of the Board.

13.0 Proof of Ability

The Tenderer will be competent and capable of performing the Work. The Tenderer is required to provide evidence of previous experience and financial responsibility before the contract is awarded.

14.0 Examination of Contract Documents and Site

- 14.1 The Tenderer will satisfy themselves as to the practicality of executing the work in accordance with the Contract, and they will be held to have satisfied themselves in every particular before making up their Tender by inquiry, measurement, calculation and inspection of the site.
- 14.2 The Tenderer will examine the site and its surroundings and, before submitting their Tender will satisfy themselves as to the nature of the site, the quantities and nature of the work and equipment necessary for the completion of the work, and the means to access to the site, the accommodation they may require, and in general, will obtain all relevant information as to risks, contingencies and other circumstances which may influence their Tender.

15.0 Liability for Errors

- 15.1 The Regional District will not be responsible for any costs incurred by Tenderers as a result of the preparation or submission of a Tender pertaining to this ITT. The accuracy and completeness of the Tender is the Tenderer's responsibility. If errors are discovered, they will be corrected by the Tenderer at their expense.
- 15.2 Tenderers acknowledge that the Regional District, in the preparation of the ITT supply of oral or written information to Tenderers, review of Tenders or the carrying out the Regional District's responsibilities under this ITT, does not owe a duty of care to Tenderers.

16.0 Limitation of Liability

Except for claims for costs of preparation of its Tender, each Tenderer, by submitting a Tender, irrevocably waives any claim, action, or proceeding against the Regional District including without limitation any judicial review or injunction application or against any of the Regional District's employees, advisors or representatives for damages, expenses or costs including costs of Tender preparation, loss of profits, loss of opportunity or any consequential loss for any reason including: any actual or alleged unfairness on the part of the Regional District at any stage of the Tender process; if the Regional District does not award or execute a contract; or, if the Regional District is subsequently determined to have accepted a noncompliant Tender or otherwise breached or fundamentally breached the terms of this ITT.

17.0 Ownership of Tenders and Freedom of Information

- 17.1 Tenders will be received and held in confidence by the Regional District, subject to the provisions of the Freedom of Information and Protection of Privacy Act and this ITT. Each Tender should clearly identify any information that is considered to be confidential or proprietary information.
- 17.2 As an exception to Tenders being received and held in confidence, Tenderers are advised and acknowledge that any contract entered into as a result of this Tender may be subject to Board approval, which may be discussed and voted on at a meeting of the Board that is open to the public. If Board approval is required, details of Tenders, including but not limited to proposed or negotiated fees, may be provided to the Board in a publicly available staff report, discussed at a Council meeting that is open to the public, and posted on a publicly available electronic agenda on the Regional District's website.

18.0 Confidentiality

In accordance with the *Freedom of Information and Protection of Privacy Act*, Tenderers will treat as confidential and will not, without prior written consent of the Regional District, publish, release, or disclose, or permit to be published, released, or disclosed, any information supplied to, obtained by, or which comes to the knowledge of a Tenderer as a result of this ITT except insofar as such publication, release or disclosure is required by the laws of British Columbia.

PART C – CONTRACT CONDITIONS

1. Form of Contract

A sample contract agreement is included as Appendix J.

2. Start and Duration of Contract

The term of the Contract will begin on September 23, 2024 at 12:01 a.m., and the Contract will remain in force until midnight on December 31, 2024.

3. Term and Termination

The term of this Contract shall commence as set out in Section 2. and shall continue in effect until terminated by either party as provided herein. Either party may terminate this Agreement at any time, with or without cause, by providing not less than 30 business days advance written notice to the other party. The Contractor or the Regional District may terminate this Agreement immediately in writing if either party becomes insolvent, enters bankruptcy, receivership, or other like proceeding (voluntary or involuntary) or makes an assignment for the benefit of creditors.

4. Intent of Contract Documents

This Contract is not an agreement of employment. The Contractor is an independent contractor, and nothing herein will be construed to create a partnership, joint venture, or agency and neither party will be responsible for the debts or obligations of the other.

5. Assignment of Contract

The Contractor will not sublet, sell, transfer, assign, or otherwise dispose of the Contract or any portions thereof, or their right, title or interest therein, or their obligations thereunder without written consent of the Regional District, except for an assignment to a bank of the payments to be received hereunder.

6. Payment

The Contractor will invoice the Regional District on a monthly basis. The invoice will itemize payment due for services delivered at the facility during the previous month on the Tender Sum in the Schedule of Prices. Invoices should quote contract number ES-24-14.

The Regional District will, by the thirtieth day of the month following that for which payment is required on receipt of an invoice and on advice from the Manager that the Work has been satisfactorily carried out, pay the Contractor for Work completed in accordance with the Contract in the previous month. No payment will be made for materials supplied by the Regional District.

7. Changes to the Contract Work

The Regional District, without invalidating the Contract, may make changes by altering, adding to, or deducting from the work. The Contractor will proceed with the work as changed and the work will be executed under the provisions of the Contract. No changes will be undertaken by the Contractor without written order of the Regional District, except in an emergency endangering life or property,

and no claims for additional compensation will be valid unless the change was so ordered. The Regional District will entertain no payment for extra work or changes in the Contract unless a "Change Order" form is completed and signed by the Regional District and the Contractor.

If, in the opinion of the Regional District, such changes affect the Contract amount, these will be adjusted at the time of ordering the changes. The value of the addition or deduction from the Contract amount will be decided by the Regional District based on a lump sum estimate submitted by the Contractor and accepted by the Regional District.

8. Insurance

The Contractor shall, without limiting its obligations or liabilities, and at its own expense, provide and maintain throughout the Contract term, the following insurance with insurers licenced in the Province of British Columbia, in forms acceptable to the Regional District. All required insurance (except automobile insurance on vehicles owned by the Contractor) shall be endorsed to show the Regional District as additional insured and to require that the Regional District be provided with 30 days' advance written notice of cancellation or material change. The Contractor will provide the Regional District with evidence of the required insurance, in a form acceptable to the Regional District, upon notification of award and prior to the execution and delivery of the Contract:

- i. Commercial General Liability (CGL) in an amount not less than \$3,000,000 inclusive per occurrence insuring against bodily injury and property damage and including liability assumed under the Contract. Such CGL coverage shall include the following liability extensions: Contingent Employers Liability, Broad Form Products & Completed Operations, Personal Injury, Blanket Contractual, and Cross Liability. The Regional District is to be added as an additional insured.
- ii. Where the Contractor requires the use of Automobiles to undertake the work of the Contract, the Contractor will have the following:
 - a. Automobile Liability on all vehicles owned, operated, or licenced in the name of the Contractor in an amount not less than \$2,000,000 per occurrence.
 - b. Non-owned Automobile Liability insurance in an amount not less than \$2,000,000 per occurrence.
- iii. Equipment insurance on all equipment owned or rented by the Contractor to its full insurable value.

The Contractor shall ensure that all sub-contractors forming from this Contract meet the insurance requirements outlined above.

It is the sole responsibility of the Contractor to determine if additional limits of liability insurance coverage are required to protect them from risk.

9. Damage to Existing Property

In the event of damage to the Regional District's property arising from actions of the Contractor, the procedure will be as follows:

1. The Contractor will immediately advise the Regional District of any damage to the Regional District's property.

2. Upon investigation, the Regional District will notify the Contractor of damages to be repaired.
3. If the Contractor does not reply within 72 hours, the Regional District will repair to the appropriate specifications or regulations and deduct the cost of the repair from payment to the Contractor.

10. WorkSafeBC

The Contractor will use due care and take all necessary precautions to assure the protection of persons and property while undertaking the Work and will comply with the Workers Compensation Act of the Province of British Columbia.

Prior to undertaking any of the Work in this Service Agreement, the Contractor will provide the Regional District with a Clearance Letter confirming they are in good standing with WorkSafeBC and will pay and keep current all assessments required by WorkSafeBC in relation to the Service Agreement amount.

Out of Province Contractors will be compliant with WorkSafeBC's registration requirements pertaining to out-of-province firms. Where WorkSafeBC registration requirements allow for a Contractor to be registered with another Province's Worker's Compensation Board or like organization, the Contractor will provide the Regional District with their registration number and written documentation confirming that the Contractor is in good standing with the appropriate Worker's Compensation Board, or like organization. The Contractor will pay and keep current all assessments required to maintain good standing in relation to the Service Agreement amount.

11. Indemnity and Release by Contractor

Notwithstanding the compliance of the Contractor with all the clauses concerning insurance, the Contractor shall indemnify, protect, and save harmless the Regional District, its officials, officers, employees, volunteers, servants, and agents from and against any and all liabilities, damages, losses, claims, costs, expenses of any kind whatsoever (including legal costs), and actions recoverable by any third party from the Regional District, arising from or caused by a negligent act or omission of, or breach of this Agreement on the part of, the Contractor, and shall be paid by the Contractor. If the Regional District pays, or is required to pay, any damages, costs, or fees on account of the actions, claims and demands herein recited, or if the property of the Regional District shall be charged in any way as a result of the aforesaid actions, causes of actions, and claims for demands, then the Regional District shall be entitled to recover from the Contractor all such damages, costs, fees or other charges together with any costs or expenses incurred in so doing. The Contractor covenants and agrees that this clause shall survive the termination of the Contract herein granted.

12. Force Majeure

If either the Contractor or the Regional District are prevented from performing their obligations under the Contract, or where the Regional District's work in respect of which the Contractor is providing Services cannot be performed, because of an act of God, an act of a legislative, administrative or judicial entity, fire, flood, labour strike or lock-out, epidemic, unusually severe weather, or other similar cause outside of the control of the Parties (collectively "Force Majeure"), then the obligations of the Contractor and the Regional District under the Contract shall be suspended for so long as the condition constituting Force Majeure continues. The Party affected by Force Majeure shall provide

the other Party with notice of the anticipated duration of the Force Majeure event, any actions being taken by the Party providing notice to avoid or minimize the effect of the Force Majeure event and shall make reasonable efforts to remove or mitigate the effects of the condition constituting Force Majeure. Upon the termination of the Force Majeure event, the Regional District shall grant to the Contractor a time extension for performance of any milestone dates required as part of the Services as may be agreed with the Contractor or, if the Regional District and the Contractor are unable to reach agreement, as determined by the dispute resolution process under Section 22 of the Contract. Where as a result of Force Majeure there is a material increase in the Contractor's cost of or the time required for the performance of the Services that is not offset by a decrease in cost, then the Regional District shall increase the amount of the service fee payable to the Contractor under Section 6 of this Agreement, as may be agreed by the Contractor, or as determined under Section 22 of the Contract. If the event of Force Majeure results in a material increase in the cost of the work to be performed in respect of which the Contractor is providing the Services, then the Regional District may choose not to proceed with the completion of the work and may terminate this Agreement. If the Regional District terminates this Agreement following the termination of the Force Majeure event, then it shall compensate the Contractor in accordance with Section 3 of this Agreement.

13. Ownership and Freedom of Information

13.1 Tenders will be received and held in confidence by the Regional District, subject to the provisions of the Freedom of Information and Protection of Privacy Act and this ITT. Each Tender should clearly identify any information that is considered to be confidential or proprietary information.

13.2 As an exception to Tenders being received and held in confidence, Tenderers are advised and acknowledge that any contract entered into as a result of this Tender may be subject to Board approval, which may be discussed and voted on at a meeting of the Board that is open to the public. If Board approval is required, details of Tenders, including but not limited to proposed or negotiated fees, may be provided to the Board in a publicly available staff report, discussed at a Council meeting that is open to the public, and posted on a publicly available electronic agenda on the Regional District's website.

14. Rights of Waiver

A waiver, or any breach of any provision of this ITT, will not constitute or operate as a waiver, or any other breach, of any other provisions, nor will any failure to enforce any provision herein operate as a waiver of such provisions or of any other provisions.

15. Severability

All paragraphs of the Contract are severable one from the other. Should a court of competent jurisdiction find that any one or more paragraphs herein are void or unenforceable, the validity of the remaining paragraphs hereof will not be affected.

16. Independent Contractor

The Contractor shall be fully independent and shall not act as an agent or employee of the Regional District. The Contractor shall be solely responsible for its employees, and any subcontracts the Contractor lets, and for their compensation, benefits, contributions, and taxes, if any.

17. Character of Workers

The Contractor and workers must have sufficient knowledge, skill, and experience to perform properly the work assigned to them and to be tactful and courteous in dealing with the public and the Regional District's staff. Any supervisor or worker employed by the Contractor or Sub-Contractor who, in the opinion of the Owner, does not perform their work in a competent manner, appears to act in a disorderly or intemperate manner, appears to be under the influence of drugs or alcohol, or is negligent, or willfully misconducts themselves will, at the written request of the Owner, be removed from the site of the work immediately and will not be employed again in any portion of the work without the approval of the General Manager of Environmental Services.

18. Assignment and Subcontracting

This Agreement does not create any right or benefit in anyone other than the Regional District and the Contractor and shall not be assigned by either party without the prior written approval of the other party.

19. Regional District's Termination of Contract

In the event of the breach or non-performance by the Contractor of any of the covenants, conditions, and agreements contained in the Contract to be performed, the Regional District reserves the right to terminate this Contract without notice. The Regional District may also deduct from the payments due to the Contractor any payments or expenditures it is required to make to remedy any such non-performance or breach hereof.

20. Contractor's Termination of Contract

The Contractor shall have the right to terminate the Contract in the event the Regional District fails to pay for the Work performed except as provided in the Contract Documents within 30 days from the specified date of payment and fails to remedy such default within 10 days of the Contractor's written notice to do so.

21. Regional District's Right to Correct Deficiencies

The Regional District shall have and retain full authority to inspect the work of the Contractor to ensure that the requirements of the Contract are being fulfilled. Upon failure of the Contractor to perform the work in accordance with the Contract Documents, and after five days written notice to the Contractor, or without notice if any emergency or danger to the work or public exists, the Regional District may, without prejudice to any other remedy they may have, correct such deficiencies. The cost of Work performed by the Regional District in correcting deficiencies shall be paid by the Contractor or may be deducted from monies payable to the Contractor.

22. Dispute Resolution

If a claim, dispute, or controversy arises out of or relates to the interpretation, application, enforcement, or performance of services under this agreement, the Contractor and the Regional District agree first to try in good faith to settle the dispute by negotiations between the Contractor and the Regional District. If such negotiations are unsuccessful, the Contractor and the Regional District agree to attempt to settle the dispute by arbitration if both parties agree. If the dispute cannot be settled through arbitration, the Contractor and the Regional District may agree to attempt to settle

the dispute through good faith mediation. If the dispute cannot be resolved through mediation and unless otherwise mutually agreed, the dispute shall be settled by litigation in an appropriate court in the Province of British Columbia.

23. Permit and Regulations

The Contractor will, at their own expense unless pre-approved in writing by the Regional District, procure all other permits, certificates, and licenses required by law for the execution of the work and will comply with all federal, provincial, and local laws and regulations affecting the execution of the work, save in so far as the Contract Documents specifically provide otherwise.

24. Scope of Work

This contract encapsulates Phase One of a multi-phase project for fencing the new parking areas at the Regional District's 155 George Street Office building in Prince George. Phase One includes the labour, preliminary works, materials, and equipment necessary to meet the requirements in Appendix K – Specifications, to supply and install:

- 55 metres of commercial ornamental black coated steel fencing- eight foot (height) 3-rail;
- a matching sliding cantilever gate (7.9 m Ameristar Transport Traverse II Gate) with IHSL24UL Liftmaster Operator (automatic gate opener) and remote-control access that functions with the existing Dominion St. gate opener; and,
- a matching accessible swing gate with FOB reader that functions with the existing FOB system used for the building.

The tenderer is being asked to provide costing where the Ameristar Montage Commercial Majestic fence is the basis of design for this work. The system shall include all components (i.e., panels, posts, gates, and hardware).

This bid is open to other comparable manufacturers offering very similar type products; however, their products must be submitted to the Regional District for approval during the bid phase as an allowable substitution request. The Regional District will respond via addendum to confirm if substitution is acceptable or not. Aluminum will not be an acceptable alternate material. Substitute manufacturers must have materials ready to ship to meet project timelines.

The Contractor will inspect the site and provide any questions or concerns to the Regional District at the start of work.

The Contractor will:

- Upon receipt at the job site, all materials shall be checked to ensure that no damage occurred during shipping or handling. Materials shall be stored in such a manner to ensure proper ventilation and drainage, and to protect against damage, weather, vandalism and theft.
- When cutting/drilling rails or posts adhere to the following steps to seal the exposed steel surfaces:
 - Remove all metal shavings from cut area.
 - Apply zinc-rich primer to thoroughly cover cut edge and/or drilled hole; let dry.
 - Apply 2 coats of custom finish paint matching fence color. Failure to seal exposed surfaces per steps 1-3 above will negate warranty.
 - Ameristar spray cans or paint pens shall be used to prime and finish exposed

surfaces; it is recommended that paint pens be used to prevent overspray. Use of non-Ameristar parts or components will negate the manufactures. warranty.

- Auger all post holes. 8" diameter for all line posts and corner posts, 12" diameter for the 24' gate posts. The 12" gate posts will be at a depth of 6' with a small footing on each to help prevent any settling/lifting of the post which could cause misalignment.
- All post holes will be filled with 3000psi concrete to just above finish grade and crowned for positive drainage away from posts.
- All spoils from post holes will be scattered.
- There is a requirement for the use of sonotubes to a depth of 42" to meet frost protection requirements.
- Contractor shall install all posts plumb and level.
- Care shall be taken to remove any excess concrete splattered on exposed finish post surfaces. It is noted that a concrete truck will be able to drive the fence line for the placement of concrete.

Time is of the essence with this project. The Regional District would like this work completed before winter sets in.

Product Warranty

- a. All structural fence components (i.e. rails, pickets, and posts) shall be warranted within specified limitations, by the manufacturer for a period of 20 years from the date of original purchase. The warranty shall cover any defects in the material finish, including cracking, peeling, chipping, blistering or corroding.
- b. Reimbursement for labor necessary to restore or replace components that have been found to be defective under the terms of manufactures warranty shall be guaranteed for five years from date of original purchase.

25. Project Manager's Status

The Project Manager or their delegate will be the Regional District's representative during the period of operation and will observe the Work in progress on behalf of the Regional District for the purpose of ensuring that the Work has been satisfactorily carried out. The Project Manager will have the authority to stop the Work whenever such a stoppage may be necessary, in their opinion, to ensure the proper execution of the Work in accordance with the provisions of the Contract.

If at any time the Project Manager is of the opinion that there exists a danger to life or to property, they may order the Contractor to stop Work or to take such remedial measures as is considered necessary.

The Contractor will comply with such an order immediately. Neither the giving nor the carrying out of such orders thereby entitles the Contractor to any extra payment, and the Regional District will not be held liable for any damages or any breach of laws, bylaws or regulations that may result.

26. Protection of Work and Property

The Contractor shall take all reasonable precautions necessary to protect the Regional District's property from damage during the performance of the Contract and shall make good on any damage to the Regional District's property caused by the Contractor, its Sub-Contractor, employees, or agents during the performance of the Contract.

27. Occupational Health and Safety

The Contractor will ensure that they follow all occupational health and safety policies and procedures established by the Regional District. Contractors, their employees, or agents not complying with the Regional District's health and safety expectations will be required to stop Work. They will not be allowed to resume Work until the safety requirements are met.

28. Goods and Services Tax (GST)

Federal law states that a 5% tax be paid on all goods and services. If the Contractor does not qualify as a small supplier, then the Contractor is required to identify the tax (GST/PST, as applicable) on all invoices, and the Regional District is liable to pay this amount to the Contractor.

29. Disputed Work

If, in the opinion of the Contractor, they are being required to perform work beyond that which the Contract requires him to do, whether at the discretion of the Regional District or otherwise, they will, within five days, deliver to the Project Manager a written notice of protest in the form prescribed herein prior to proceeding with any of the disputed work. The five-day time period commences from the time of direction given by the Manager or the time at which the Contractor determines that he is required to perform such work, whichever occurs first.

The Contractor will keep accurate and detailed cost records that should indicate the cost of the work done under protest. The Contractor will not be entitled to payment if they fail to keep and produce such records.

30. Notice of Protest

TO:	General Manager of Environmental Services Regional District of Fraser-Fort George
FROM:	(Contractor)
DATE:	
SUBJECT:	THE CONTRACT
Date of Direction:	
You have required me to perform the following work that is beyond the scope of the Contract. (Set out details of work). (Include dates where applicable)	
The additional costs and claim for this work is as follows: (Set out details of cost)	
All supporting documentation and invoices are attached.	
I understand that I am required to keep accurate and detailed cost records, which will indicate the cost of the work done under protest, and failure to keep such records will be a bar to any recovery by me.	
Signature of Contractor	

APPENDIX B – BIDDER CHECKLIST

Before submitting your tender bid, check the following points:

- | | | |
|--------------------------|--|-------|
| <input type="checkbox"/> | Has the Tender Form been signed and witnessed? | _____ |
| <input type="checkbox"/> | Is the Schedule of Prices completed? | _____ |
| <input type="checkbox"/> | Are the following pages included? | |
| | • Schedule of Prices – Tendered Price | _____ |
| | • List of Contractor's Personnel | _____ |
| | • List of Subcontractors | _____ |
| | • Tenderer's Experience in Similar Work | _____ |
| | • Goods and Services Tax Information | _____ |
| | • Conflict of Interest Disclosure Statement | _____ |
| | • Addendum(s) | _____ |
| <input type="checkbox"/> | Are the documents complete? | _____ |
| <input type="checkbox"/> | Are the documents enclosed in a sealed envelope? | _____ |

Note: Your Tender may be disqualified if ANY of the applicable foregoing points have not been complied with.

If submitting by hard copy:

Tenderers should ensure that the Tender is returned in a sealed envelope clearly marked on the outside with:

- Attention: General Manager of Financial Services
Regional District of Fraser-Fort George
155 George Street
Prince George, BC
V2L 1P8
- INVITATION TO TENDER - ES-24-14
Supply and Install Phase One Parking Lot Fencing - 155 George Street, Prince George
- Responding Organization's name and address.

If submitting by email:

Tenderers should ensure that the files should not collectively exceed 35MB. Tenders must be submitted to purchasing@rdffg.bc.ca. DO NOT deliver a physical copy of the tender package to the Regional District of Fraser Fort George.

Subject of the file to be:

ES-24-14 Supply and Install Phase One Parking Lot Fencing - 155 George Street,
Prince George (Insert Responding Tenderer's Name)

APPENDIX C – TENDER FORM

Date: _____

Regional District of Fraser-Fort George
3rd Floor, 155 George Street
Prince George, BC V2L 1P8

ATTENTION: General Manager of Financial Services

Dear Sir/Madam:

Having carefully examined the Instructions to Tenderers, Form of Tender, Contract Agreement, General Conditions of Contract and Operational Specifications and subsequent written Addendum(s) (if any), and having visited the site(s) for purposes of examining site conditions and having satisfied myself/ourselves as to the sufficiency of the ITT, the undersigned agrees to furnish all labour, transportation, equipment, materials, supervision and services and to do all work necessary for and reasonably incidental, as specified in accordance with the ITT, to do the work.

I/We agree that in consideration of having my/our tender submission considered for the Total Contract Price as shown on the Schedule of Prices, this price is open for acceptance for 60 days from the date of the tender opening and will not be withdrawn during that period of time.

It is understood that payment will be made for the work on the basis of the awarded Contract only and that any approved extras or refunds will be made by mutual agreement between the Regional District and me/us.

I/We agree that the Subcontractor(s) employed will be as listed on the List of Subcontractors and further agree that no changes or additions will be made to the list without written approval of the Regional District.

If I am/we are notified in writing of the acceptance of our tender, I/we agree that within 14 days of the date of the acceptance notice I/we will enter into a contract and execute an agreement for the stated sum in the form of the specimen submitted to guarantee completion of the contract in accordance with the contract documents and within the time stated in the Tender documents.

I/We agree that the Regional District reserves the right to waive informalities in tenders, reject any or all tenders, or accept the tender deemed most favourable in the interests of the Regional District.

I/We agree that tenders which contain qualifying conditions or otherwise fail to conform to the instructions contained in this ITT may be disqualified or rejected. I/We agree that the Regional District may, however, in its sole discretion, reject or retain for its consideration tenders which are non-conforming because they do not contain the content or form required by the ITT, or for failure to comply with the process for submission set out in the ITT, whether or not such non-compliance is material.

I/We agree that except for a claim for the reasonable cost of preparation of this tender, by submitting a tender, I/We irrevocably waive any claim, action, or proceeding against the Regional District

including, without limitation, any judicial review or injunction application, and any claim against the Regional District and its elected officials, officers and employees for damages, expenses or costs, loss of profits, loss of opportunity or any consequential loss for any reason, including any such claim, action or proceeding arising from:

- 1) any actual or alleged unfairness on the part of the Regional District at any stage of the tender process, including without limitation any alleged unfairness in the evaluation of a tender or award of a contract;
- 2) a decision by the Regional District not to award a contract to that tenderer; or
- 3) the Regional District's award of a contract to a tenderer whose tender does not conform to the requirements of this ITT.

I/We hereby acknowledge receipt and inclusion of the following Addendum(s) to the ITT Documents:

Addendum No. _____ dated: _____ Addendum No. _____ dated: _____

Addendum No. _____ dated: _____ Addendum No. _____ dated: _____

Addendum No. _____ dated: _____ Addendum No. _____ dated: _____

Signed and Delivered by:

Signature of Authorized Signatory

Name of Tenderer

Name of Authorized Signatory (Please print)

Address

Title

City, Province, Postal Code

Signed in the presence of:

Signature

Address

Name of Witness (Please print)

City, Province, Postal Code

APPENDIX D - SCHEDULE OF PRICES – TENDERED PRICE

Tender Price

Lump sum tendered price for [INSERT PROJECT]
(excluding GST) \$ _____

GST \$ _____

Total including GST \$ _____

TOTAL Contract Value (including GST) \$ _____

APPENDIX E - LIST OF CONTRACTOR'S PERSONNEL

The Contractor agrees that the personnel employed by them will be as listed below and further agrees that any changes or additions made to this list will be made in writing to the Regional District.

Name of Employee	Employee's Experience / Qualifications

Name of Onsite Supervisor	Supervisor's Experience / Qualifications

APPENDIX F - LIST OF SUBCONTRACTORS

The Contractor agrees that the Subcontractors engaged by it will be as listed below and further agrees that any changes or additions made to this list will be made in writing to the Regional District.

Name of Subcontractor	Address of Subcontractor	Work to Be Performed by Subcontractor

APPENDIX G - TENDERER'S EXPERIENCE IN SIMILAR WORK

The Contractor is to demonstrate that they have a minimum of five years of current customer service experience as well as staff supervision experience. List professional and recent experience.

Year	Work Performed	Reference Contact (name and phone number)	Value

APPENDIX H - CONFLICT OF INTEREST STATEMENT

ES-24-14
Supply and Install Phase One Fencing – 155 George Street, Prince George

Bidder Name: _____

The Bidder, including its officers, employees, and any person or other entity working on behalf of or in conjunction with, the Bidder on this Procurement Process:

- is free of any conflict of interest that could be perceived to improperly influence the outcome of this procurement process.
- has not, and will not, participate in any improper procurement practices that can provide the Bidder with an unfair competitive advantage including obtaining and using insider type information to prepare a solicitation offer or participating in bid rigging.
- has an actual, perceived or potential conflict of interest regarding this procurement process as a result of:

State reason(s) for Conflict of Interest:

By signing below I certify that all statements made on this form are true and correct to the best of my knowledge.

Print Name of Person Signing Disclosure

Authorized Representative of

Signature of Person Making Disclosure

Date Signed

APPENDIX I - GOODS AND SERVICES TAX INFORMATION

Supplier: _____
Name _____
Address _____
City _____ Province _____
Postal Code _____ Phone Number _____

Are you a GST Registrant? Yes _____ No _____

If YES, please indicate your registration number: _____

If NO, please fill in the following (check appropriate box):

- Supplier qualifies as a small supplier under s. 148 of the legislation
- Other: Specify _____

Signature of Authorized Person Print Name

Title Date

APPENDIX J - CONTRACT AGREEMENT

BETWEEN:

REGIONAL DISTRICT OF FRASER-FORT GEORGE, a local government incorporated pursuant to the *Local Government Act* and having its business office located at:
155 George Street
Prince George, BC V2L 1P8

(hereinafter called "the Regional District")

OF THE FIRST PART

AND:

CONTRACTOR
a company duly incorporated under the laws of British Columbia and having a place of business at:
address
address, pc

(hereinafter called the "Contractor")

OF THE SECOND PART

WITNESSETH that the Contractor and the Regional District undertake and agree as follows:

1. The Contractor will:
 - (a) Provide all necessary labour, equipment, transportation, materials, supervision, and services to perform all of the work, and fulfill everything as set forth in, and in strict accordance with, the Contract documents for "Invitation to Tender ES-24-14 – Supply and Install Phase One Parking Lot Fencing – 155 George Street, Prince George.
 - (b) Commence to actively proceed with the work of the Contract September 23, 2024.
2. The Regional District will pay to the Contractor as full compensation for the performance and fulfilment of this Contract, the sum or sums of money specified herein in the manner and at the times specified in the Contract Documents.
3. The Invitation and Instructions to tenderers, Tender Form, List of Contractors Personnel, List of Subcontractors, Tender's Experience in Similar Work, Schedule of Prices, Conflict of Interest Statement, Goods and Services Tax Information, all appendices, amendments and Addendum(s), as well as the tenderer's submission, are incorporated herein, to the intent and purpose as though recited in full herein, and the whole will form the Contract and will endure to the benefit of, and be binding upon, the parties hereto and their successors, executors, administrators, and assigns.
4. No implied contract of any kind whatsoever, by or on behalf of the Regional District, will arise or be implied from anything contained in this Contract or from any position or situation of the parties at any time, it being understood and agreed that the express contracts, covenants and

agreements made herein by the parties hereto are, and will be, the only contract, covenants and agreements on which any rights against the Regional District may be founded.

5. Subject to Clause 4, this Contract will supersede all communications, negotiations, and agreements, either written or verbal, made between the parties hereto in respect of matters pertaining to this Contract prior to the execution and delivery hereof.
6. All communications in writing between the parties will be deemed to have been received by the addressee if delivered to the individual, or to a member of a firm, or to the General Manager of the Regional District for whom they are intended, or if sent by hand delivery, mail or registered mail as follows:

The contractor at _____
address

The Regional District at 155 George Street, Prince George, BC V2L 1P8.

IN WITNESS WHEREOF the parties have duly executed this Contract.

SIGNED ON BEHALF OF THE)
REGIONAL DISTRICT OF FRASER-FORT GEORGE)
)

_____))
GM of Environmental Services) Date
)

_____))
GM of Legislative and Corporate Services) Date
)
)

SIGNED ON BEHALF OF)
CONTRACTOR)
)
)
)
)

_____))
Signature) Date
)
)
)

(Name and Title) (Please print)

APPENDIX K – SPECIFICATIONS

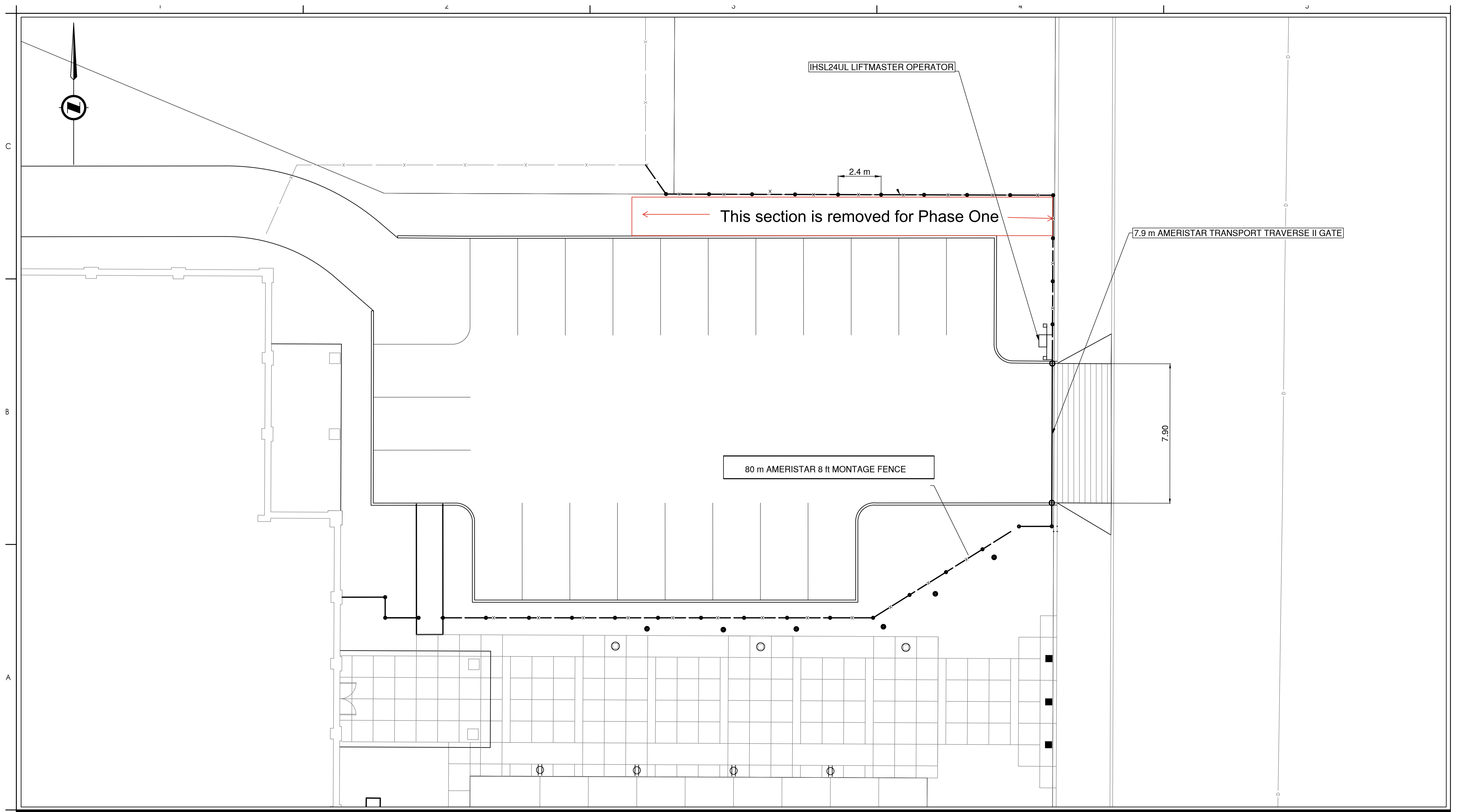

AMERISTAR FENCE PRODUCTS

Montage Commercial – Commercial Steel Ornamental Fence System – Fusion Welded and Rackable CONSTRUCTION SPECIFICATION - SECTION 32 31 00

PART 1 - GENERAL

1.01 WORK INCLUDED

The contractor shall provide all labor, materials and appurtenances necessary for installation of the welded ornamental steel fence system defined herein at (specify project site).

1.02 RELATED WORK

Section ____ - Earthwork

Section ____ - Concrete

1.03 SYSTEM DESCRIPTION

The manufacturer shall supply a total fence system of (specify Montage Commercial® standard picket space or Montage Commercial® Pool, Pet & Play® 3” air space) **Welded and Rackable** (ATF – All Terrain Flexibility) Ornamental Steel (for standard picket space, specify Classic™, Majestic™, Genesis™, or Invincible®; for 3” air space, specify Classic™, Majestic™, or Genesis™) design. The ornamental fence system shall be (specify 7’ height or 8’ height) from grade. The system shall include all components (i.e., panels, posts, gates and hardware) required.

1.04 QUALITY ASSURANCE

The contractor shall provide laborers and supervisors who are thoroughly familiar with the type of construction involved and materials and techniques specified.

1.05 REFERENCES

- ASTM A653/A653M - Standard Specification for Steel Sheet, Zinc-Coated (Galvanized) or Zinc-Iron Alloy Coated (Galvannealed) by the Hot-Dip Process.
- ASTM B117 - Practice for Operating Salt-Spray (Fog) Apparatus.
- ASTM D523 - Test Method for Specular Gloss. 0020
- ASTM D714 - Test Method for Evaluating Degree of Blistering in Paint.
- ASTM D822 - Practice for Conducting Tests on Paint and Related Coatings and Materials using Filtered Open-Flame Carbon-Arc Light and Water Exposure Apparatus.
- ASTM D1654 - Test Method for Evaluation of Painted or Coated Specimens Subjected to Corrosive Environments.
- ASTM D2244 - Test Method for Calculation of Color Differences from Instrumentally Measured Color Coordinates.
- ASTM D2794 - Test Method for Resistance of Organic Coatings to the Effects of Rapid Deformation (Impact).
- ASTM D3359 - Test Method for Measuring Adhesion by Tape Test.
- ASTM F2408 – Ornamental Fences Employing Galvanized Steel Tubular Pickets.

1.06 SUBMITTAL

The manufacturer’s literature shall be submitted prior to installation.

1.07 PRODUCT HANDLING AND STORAGE

Upon receipt at the job site, all materials shall be checked to ensure that no damage occurred during shipping or handling. Materials shall be stored in such a manner to ensure proper ventilation and drainage, and to protect against damage, weather, vandalism and theft.

PART 2 - MATERIALS

2.01 MANUFACTURER

The fence system shall conform to (specify Montage Commercial standard picket space or Montage Commercial Pool, Pet & Play 3” air space) **Welded and Rackable** (ATF – All Terrain Flexibility) Ornamental Steel, (for standard picket space, specify Classic, Majestic, Genesis, or Invincible®; for 3” air space, specify Classic, Majestic, or Genesis) design, (specify extended picket or flush) bottom rail treatment, (specify 3-Rail, 4-Rail, or 3-Rail with Double Rings, 4-Rail with Double Rings) style manufactured by Ameristar Fence Products, Inc., in Tulsa, Oklahoma.

2.02 MATERIAL

A. Steel material for fence panels and posts shall conform to the requirements of ASTM A653/A653M, with a minimum yield strength of 45,000 psi (310 MPa) and a minimum zinc (hot-dip galvanized) coating weight of 0.60 oz/ft² (184 g/m²), Coating Designation G-60.

B. Material for pickets shall be 3/4" square x 14 Ga. tubing. The rails shall be steel channel, 1.5" x 1.4375" x 14 Ga. Picket holes in the rail shall be spaced (specify 4.675" o.c. for standard picket space or 3.500" o.c. for 3" air space). Fence posts and gate posts shall meet the minimum size requirements of Table 1.

2.03 FABRICATION

A. Pickets, rails and posts shall be pre-cut to specified lengths. Rails shall be pre-punched to accept pickets.

B. Pickets shall be inserted into the pre-punched holes in the rails and shall be aligned to standard spacing using a specially calibrated alignment fixture. The aligned pickets and rails shall be joined at each picket-to-rail intersection by Ameristar's proprietary fusion welding process, thus completing the rigid panel assembly (Note: The process produces a virtually seamless, spatter-free good-neighbor appearance, equally attractive from either side of the panel).

C. The manufactured panels and posts shall be subjected to an inline electrode position coating (E-Coat) process consisting of a multi-stage pretreatment/wash (with zinc phosphate), followed by a duplex application of an epoxy primer and an acrylic topcoat. The minimum cumulative coating thickness of epoxy and acrylic shall be 2 mils (0.058 mm). The color shall be (specify Black or Bronze). The coated panels and posts shall be capable of meeting the performance requirements for each quality characteristic shown in Table 2 (Note: The requirements in Table 2 meet or exceed the coating performance criteria of ASTM F2408).

D. The manufactured fence system shall be capable of meeting the vertical load, horizontal load, and infill performance requirements for Industrial weight fences under ASTM F2408.

E. Gates shall be fabricated using fusion welded ornamental panel material and 1-3/4" sq. x 14ga. gate ends. All rail and upright intersections shall be joined by welding. All picket and rail intersections shall also be joined by welding.

PART 3 - EXECUTION

3.01 PREPARATION

All new installation shall be laid out by the contractor in accordance with the construction plans.

3.02 INSTALLATION

Fence post shall be spaced according to Table 3, plus or minus 1/4". For installations that must be raked to follow sloping grades, the post spacing dimension must be measured along the grade. Fence panels shall be attached to posts with brackets supplied by the manufacturer. Posts shall be set in concrete footers having a minimum depth of 36" (Note: In some cases, local restrictions of freezing weather conditions may require a greater depth). The "Earthwork" and "Concrete" sections of this specification shall govern material requirements for the concrete footer. Posts setting by other methods such as plated posts or grouted core-drilled footers are permissible only if shown by engineering analysis to be sufficient in strength for the intended application.

3.03 FENCE INSTALLATION MAINTENANCE

When cutting/drilling rails or posts adhere to the following steps to seal the exposed steel surfaces; 1) Remove all metal shavings from cut area. 2) Apply zinc-rich primer to thoroughly cover cut edge and/or drilled hole; let dry. 3) Apply 2 coats of custom finish paint matching fence color. Failure to seal exposed surfaces per steps 1-3 above will negate warranty. Ameristar spray cans or paint pens shall be used to prime and finish exposed surfaces; it is recommended that paint pens be used to prevent overspray. Use of non-Ameristar parts or components will negate the manufactures' warranty.

3.04 GATE INSTALLATION

Gate posts shall be spaced according to the manufacturers' gate drawings, dependent on standard out-to-out gate leaf dimensions and gate hardware selected. Type and quantity of gate hinges shall be based on the application; weight, height, and number of gate cycles. The manufacturers' gate drawings shall identify the necessary gate hardware required for the application. Gate hardware shall be provided by the manufacture of the gate and shall be installed per manufacturer's recommendations.

3.05 CLEANING

The contractor shall clean the jobsite of excess materials; post-hole excavations shall be scattered uniformly away from posts.

Table 1 – Minimum Sizes for Montage Commercial Posts	
<u>Fence Posts</u>	<u>Panel Height</u>
2-1/2" x 14 Ga.	7' & 8' Heights
Gate Leaf	
	<u>Gate Height</u>
	7' & 8' Heights
Up to 4'	3" x 12 Ga.
4'1" to 6'	4" x 12 Ga.
6'1" to 16'	6" x 12 Ga.

Table 2 – Coating Performance Requirements		
<u>Quality Characteristics</u>	<u>ASTM Test Method</u>	<u>Performance Requirements</u>
Adhesion	D3359 – Method B	Adhesion (Retention of Coating) over 90% of test area (Tape and knife test).
Corrosion Resistance	B117, D714 & D1654	Corrosion Resistance over 1,500 hours (Scribed per D1654; failure mode is accumulation of 1/8" coating loss from scribe or medium #8 blisters).
Impact Resistance	D2794	Impact Resistance over 60 inch lb. (Forward impact using 0.625" ball).
Weathering Resistance	D822 D2244, D523 (60° Method)	Weathering Resistance over 1,000 hours (Failure mode is 60% loss of gloss or color variance of more than 3 delta-E color units).

Table 3 – Montage Commercial – Post Spacing By Bracket Type										
Span	For INVINCIBLE [®] 8' Nominal (90.445" Rail)				For CLASSIC, GENESIS, & MAJESTIC 8' Nominal (91.95" Rail)					
	2-1/2"	3"	2-1/2"	3"	2-1/2"	3"	2-1/2"	3"	2-1/2"	3"
Bracket Type	Montage Commercial Invincible Flat Mount (BB118)		Montage Commercial Invincible Line 2-1/2" (BB119) 3" (BB120)		Montage Commercial Universal (BB112)	Montage Commercial Line Blvd. (BB114)	Montage Commercial Flat Mount (BB111)		Montage Commercial Swivel (BB113)*	
Post Settings ± 1/4" O.C.	94"	94-1/2"	94"	94-1/2"	95"	95"	95"	95-1/2"	*95"	*95-1/2"
*Note: When using BB304 swivel brackets on either or both ends of a panel installation, care must be taken to ensure the spacing between post and adjoining pickets meets applicable codes. This will require trimming one or both ends of the panel.										

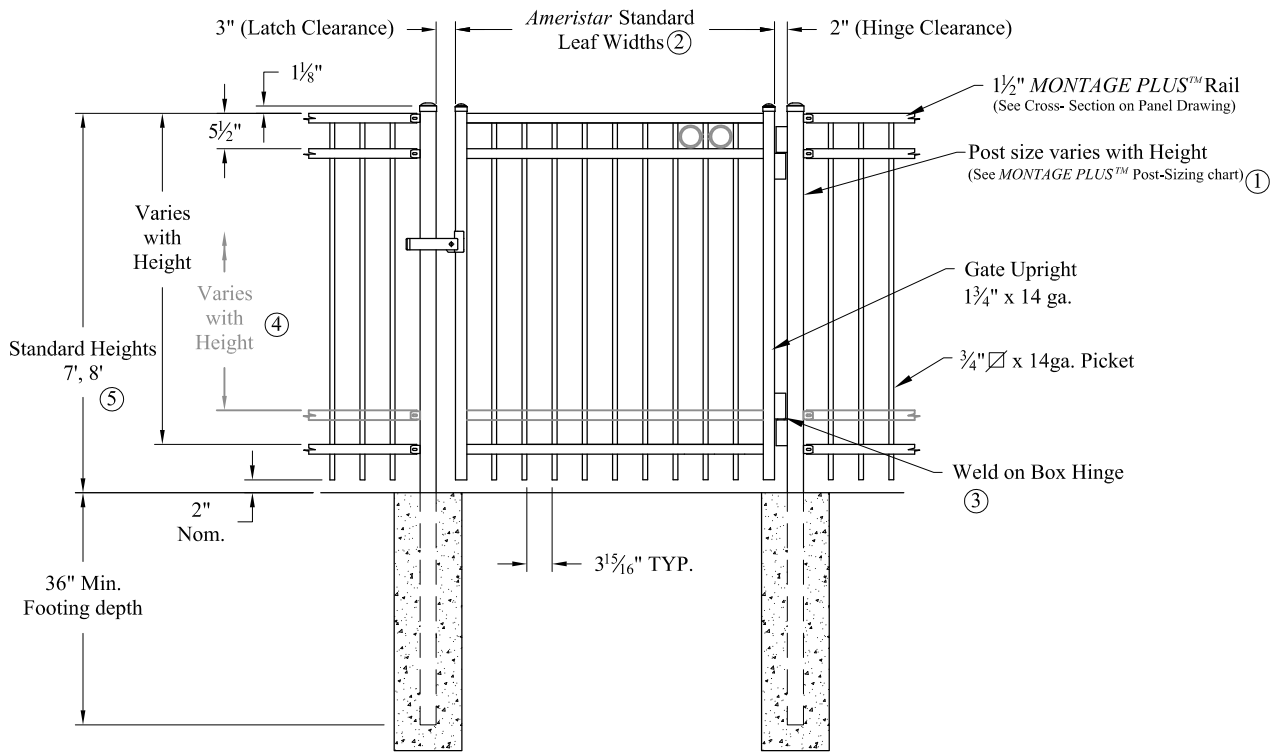

NOTES: *Single gate Arrangement*

- 1.) Post size depends on fence height, weight and wind loads. See MONTAGE PLUS™ post sizing chart.
- 2.) See Ameristar gate table for standard out to outs. Custom gate openings available for special out to out/leaf widths.
- 3.) Additional styles of gate hardware are available on request. This could change the Latch & Hinge Clearance.
- 4.) Forth rail optional.

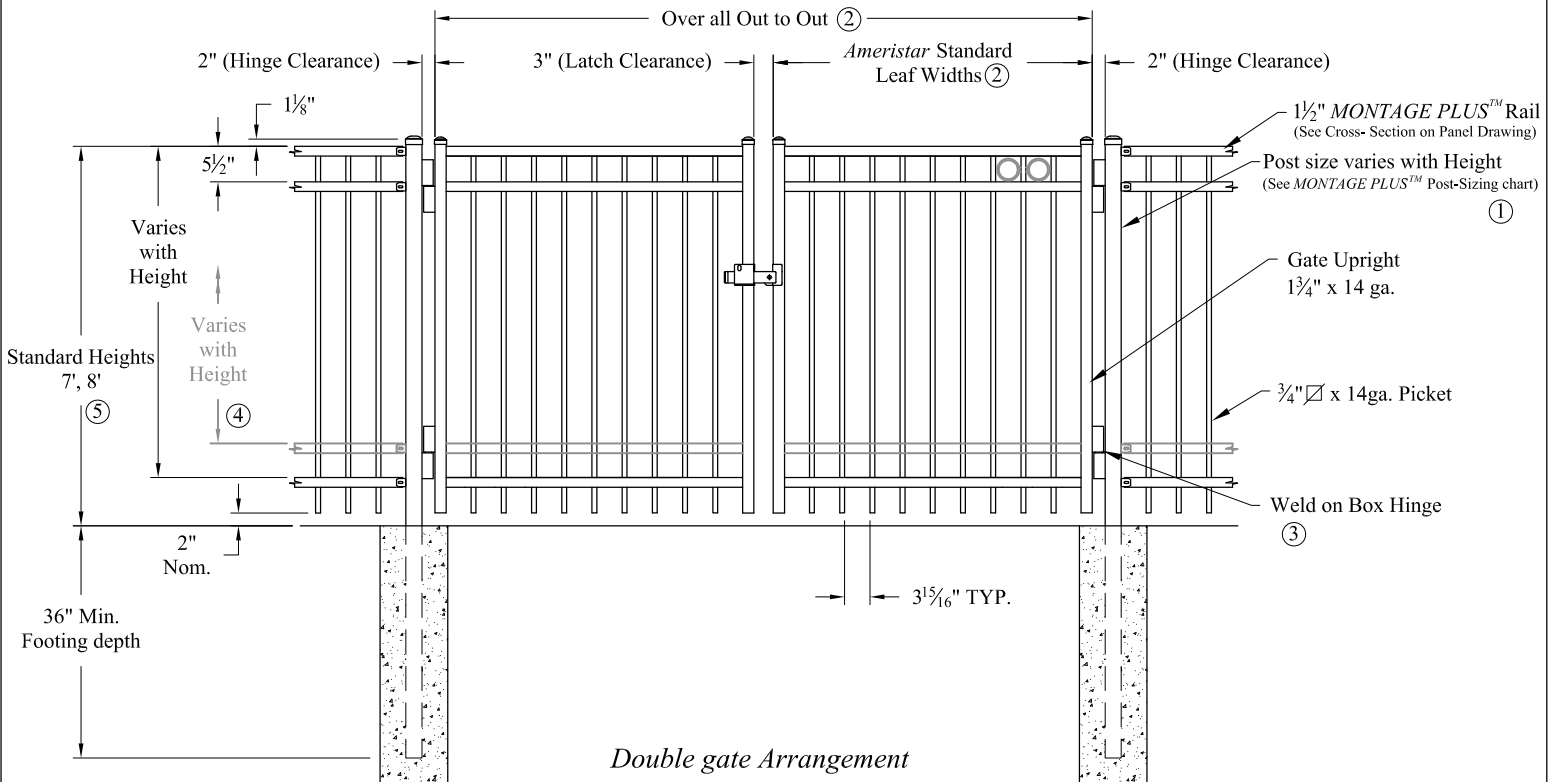

Values shown are nominal and not to be used for installation purposes. See product specification for installation requirements.

COMMERCIAL STRENGTH WELDED STEEL GATES

Title: MONTAGE COMMERCIAL MAJESTIC 3/4-RAIL SGL & DBL GATE

DR: RTM	SH . 1 of 1	SCALE: DO NOT SCALE
CK: ME	Date 6/25/10	REV: c



AMERISTAR®

1555 N. Mingo
Tulsa, OK 74116
1-888-333-3422
www.ameristarfence.com

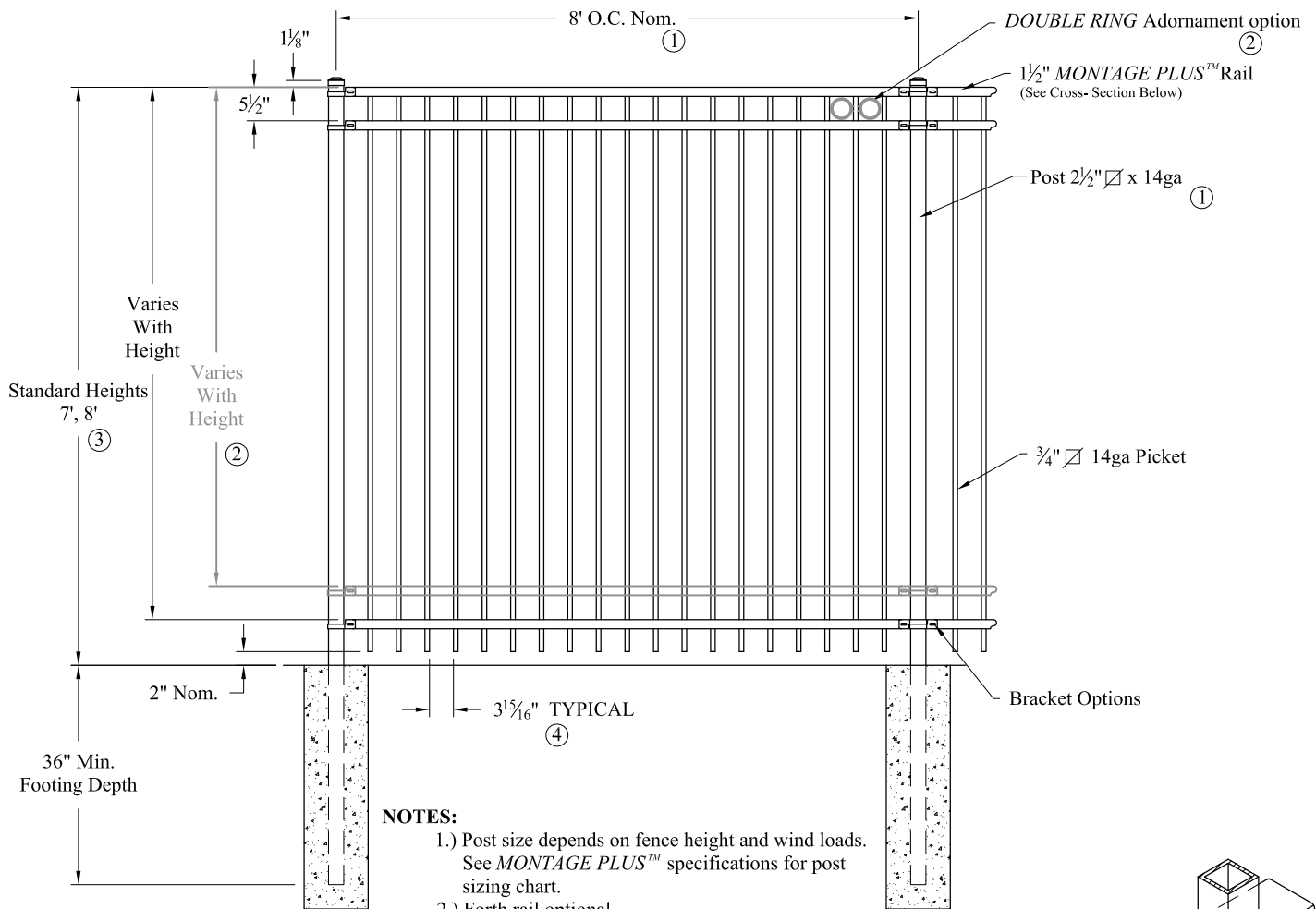

NOTES:

- 1.) Post size depends on fence height and wind loads. See MONTAGE PLUS™ specifications for post sizing chart.
- 2.) Forth rail optional.
- 3.) 7' & 8' Heights will require a 14ga Picket and 14ga Post.

RAKING DIRECTIONAL ARROW
 Welded panel can be raked 30" over 8' with arrow pointing down grade.

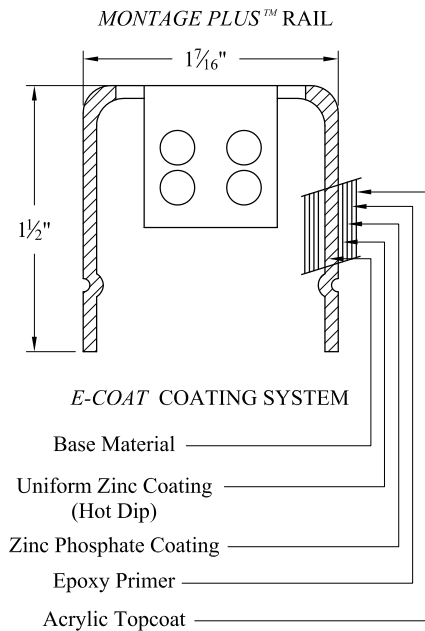

PROFUSION™ WELDING PROCESS

No exposed welds,
 Good Neighbor profile - Same appearance on both sides

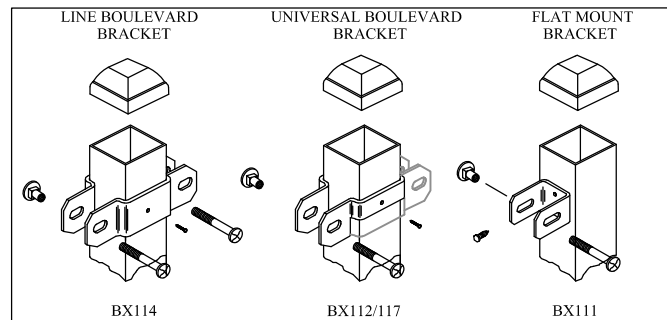
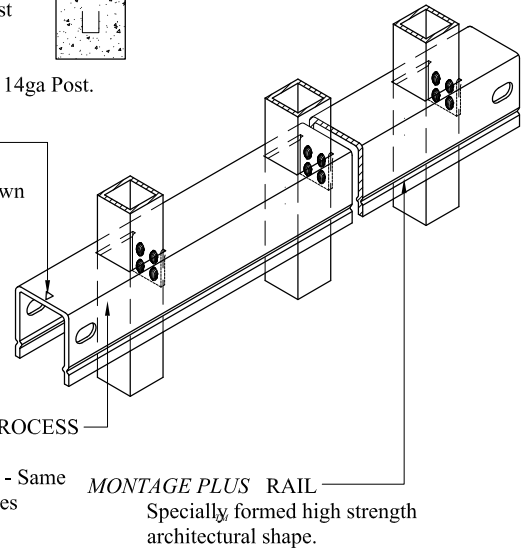

COMMERCIAL STRENGTH WELDED STEEL PANEL
PRE-ASSEMBLED

Values shown are nominal and not to be used for installation purposes. See product specification for installation requirements.

1RMISO7-8

Title: **MONTAGE COMMERCIAL MAJESTIC 3/4-RAIL**

DR: NJB SH . 1 of 1 SCALE: DO NOT SCALE

CK: BS Date 09/21/11 REV: d



AMERISTAR®

1555 N. Mingo
 Tulsa, OK 74116
 1-888-333-3422
 www.ameristarfence.com